

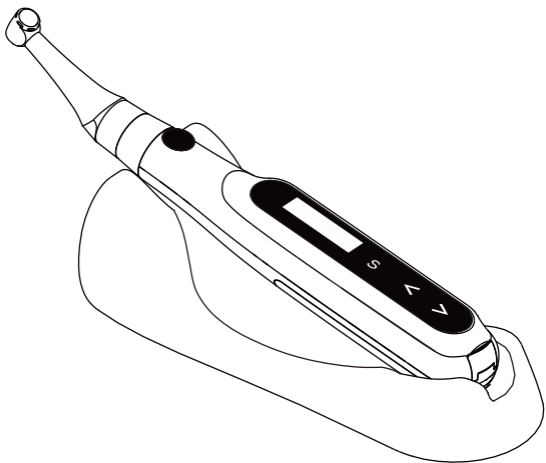

CE
0197

E-CONNECT



Endo Motor USER MANUAL

Changzhou Sifary Medical Technology Co., Ltd.

P/N: IFU-6035105
Version: 09
Issued: Nov. 18, 2022
Size:130mmX85mm

Content

1. Scope of E-CONNECT	5
1.1 Parts Identification	5
1.2 Components	6
2. Symbols Used	8
3. Before Use	10
3.1 Scope of application	10
3.2 Contraindications.....	10
4. Installing the E-CONNECT	13
4.1 Installation of the contra angle.....	13
4.2 Install and Remove the file	13
4.3 Connection Operation.....	15
4.4 E-CONNECT Charging.....	17
5. Use Interface	18
5.1 Panel key	18
5.2 Screen display	20
5.3 Display the root canal on E-CONNECT	20
5.4 Combination Function	21
5.5 Terms and definition.....	23
6. Setting.....	24
6.1 General function setting.....	24
6.2 Operation steps.....	24
6.3 Advanced setting	26
6.4 Additional function settings.....	28
6.5 Calibration.....	29
7. Error Warning	30
8. Cleaning, Disinfection and Sterilization	31
8.1 Foreword.....	31
8.2 General recommendations	31
8.3 Disinfection.....	38
9. Troubleshooting	39

10. Technical Data.....	41
11. EMC Tables	43
12. Statement	53



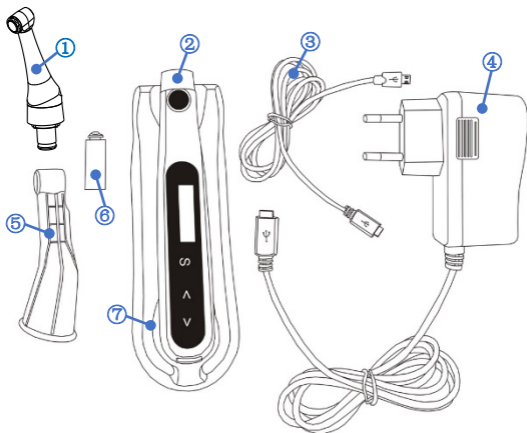

1. Scope of E-CONNECT

1.1 Parts Identification



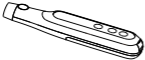

- ① Contra Angle
- ② Motor Handpiece
- ③ Data Transfer Cable
- ④ Adapter
- ⑤ Insulating Sleeve
- ⑥ Spray Nozzle
- ⑦ Handpiece Base

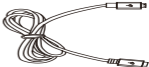



1.2 Components

<p>Motor Handpiece (1pcs) Part No:6051012</p> 	<p>Handpiece Base(1pcs) Part No:6005002</p> 	<p>Contra Angle (1pcs) Part No:6036006</p> 
<p>Insulating Sleeve (1pcs) Part No:6004027</p> 	<p>Spray Nozzle (1pcs) Part No:6051038</p> 	<p>Data Transfer Cable (1pcs) Part No :6015003</p> 



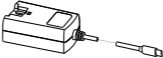













For different regions, there are several different adapter options to be selected as follows.

Standard	Adapter	Power plug
<p>European standard</p>	<p>Adapter (1pcs) Part No: 6016020</p> 	<p>/</p>
<p>American standard</p>	<p>Adapter (1pcs) Part No: 6016007</p> 	<p>American standard power plug (1pcs) Part No: 6016011</p> 





1 Scope of E-CONNECT

<p>Multi- standard</p>	<p>Adapter (1pcs) Part No:6016007</p> 	<p>British standard power plug (1pcs) Part No: 6016009</p> 
		<p>Australian standard power plug (1pcs) Part No: 6016010</p> 
		<p>Argentina standard power plug (1pcs) Part No:6016014</p> 

2. Symbols Used

	General warning sign
	Caution
	Serial number
	Catalogue number
	Medical device
	Authorized representative in the European Community
	Manufacturer
	Country of manufacture
	Class II equipment
	Type B applied part
	Keep dry
	CE marking
	Dispose of in accordance with the WEEE directive
	Direct current
	Consult instructions for use
	Manufacturer's Logo
	Sterilizable in a steam sterilizer (autoclave) at the temperature specified

2 Symbols Used

 <p>A thermometer icon with a bulb at the bottom and a scale on top. A line points to the top of the scale labeled "55°C". Another line points to the bottom of the bulb labeled "-20°C".</p>	Temperature limit
 <p>A circular symbol containing a percentage sign (%). A wavy line is drawn across the bottom of the circle. A line points to the top of the circle labeled "80%". Another line points to the wavy line labeled "20%".</p>	Humidity limitation
 <p>A circular symbol containing two horizontal arrows pointing towards each other. A line points to the top of the circle labeled "106 kPa". Another line points to the bottom of the circle labeled "70 kPa".</p>	Atmospheric pressure limitation
 <p>A square symbol with a stylized icon inside. The icon consists of a vertical line with a horizontal bar at the top, resembling a spray nozzle or a disinfection head.</p>	Washer-disinfector for thermal disinfection

3. Before Use

3.1 Scope of application

Use for dental root canal treatment using endodontic instruments in torque controlled continuous rotation and in reciprocating movement.

This device must only be used in hospital environments, clinics or dental offices by qualified dental personnel and not used in the oxygen-rich environment.

3.2 Contraindications

Do not use E-CONNECT together with high frequency surgical equipment. Patients with heart disease should be cautious. The E-CONNECT is contraindicated in cases where patient/user carry medical implants such as pace makers or cochlear implants etc.

Do not use the device for implants or other non-endodontic dental procedures.

Safety and effectiveness have not been established in pregnant women and children.



Read the following warnings before use:

- The device must not be placed in humid surroundings or anywhere where it can come into contact with any type of liquids.
- Do not expose the device to direct or indirect heat sources.
- Do not use the device in the presence of free oxygen, anesthetic gas or combustible materials. The device must be operated and stored in a safe environment.
- The device requires special precautions with regard to electromagnetic compatibility (EMC) and must be installed and operated in strict compliance with the EMC information. In particular, do not use the device

in the vicinity of fluorescent lamps, radio transmitters, remote controls and do not use this system near the active HF Surgical Equipment in the hospital. Portable RF communications equipment (including peripherals such as antenna cables and external antennas) should be used no closer than 30 cm (12 inches) to any part of the E-CONNECT, including cables specified by the manufacturer. Otherwise, degradation of the performance of this equipment could result. Do not charge, operate or store at high temperatures. Comply with the specified operating and storage conditions.

- Please do not charge, use or store this device at high temperature. Please pay attention to the use and storage conditions.
- Gloves and a rubber dam are compulsory during treatment.
- Never open or repair the device yourself, otherwise, void the warranty.
- If irregularities occur in the device during treatment, switch it off. Contact the agency.
- Please use the original power adapter when charging.
- If liquid flows out of the handpiece, it can be judged as battery leakage. Please stop using immediately and contact the local dealer for treatment.
- Do not dismount the contra angle during the operation of the main engine, otherwise the contra angle and motor gear will be damaged.
- Please use the original contra angle, which gear ratio is 1:1. The contra angle is not field repairable.
- Use continuous file in continuous mode; use reciprocating file in reciprocating mode, and use according to rotation speed, torque and contra angle recommended by the root canal file manufacturer.
- The user or patient should report any serious incident that has occurred in relation to the device to the manufacturer and the competent authority of the Member State in which the user or patient is established.
- If the package or equipment is damaged, contact the supplier or

manufacturer.

- Before use, please confirm whether the device connection is loose, if any abnormality is found, please contact the supplier or manufacturer.
- It is forbidden to use non-original parts for the equipment.
- Do not load and use the device for a long time. Otherwise, the temperature of the device will rise, which may cause minor burn to the operator or the patient. (The surface of some applied parts, such as contra angle, will reach maximum to 48°C if loading the device continuously for more than 1 minute. The surface temperature of the motor handpiece will reach maximum to 45°C if loading the device continuously for more than 10 minutes.)

4. Installing the E-CONNECT

4.1 Installation of the contra angle

Connect the contra angle and handpiece properly.

*Make sure the motor is stopped when installing the contra angle.

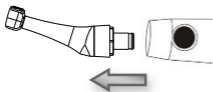

*Use the manufacturer specific contra angle.

The contra angle can be 360 degrees rotated without being taken off. Make it easy to watch the display in treatment by rotating the contra angle.

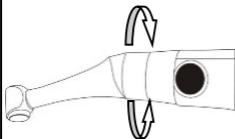

4.2 Install and Remove the file

Install the file: Insert the file and turn the file, make sure that file is inserted.

Remove the file: Keep pressing the bottom and release file.

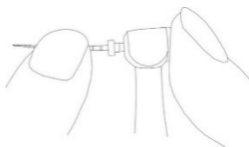

- Inspect the file head before inserting the file. Do not use the damaged file head.
- Make sure that the motor is stopped when inserting and removing files.
- Be careful when inserting and removing files to avoid injury to fingers.

4 Installing the E-CONNECT

- Take care not to touch the Main switch when installing files, which will cause the file to rotate.
- Pull the file gently to make sure that the file is installed securely in handpiece, otherwise, it may pop out and hurt the patient.



- Pay attention to avoid finger injuries when inserting or removing the files.
- File insertion or removal without pressing bottom of head will damage the spindle.
- Make sure that the motor is not running when inserting or removing the files.

4.3 Connection Operation

Make sure E-CONNECT is in standby.

Open rubber cover, plug in data transfer cable.



Turn on the E-PEX. Insert the other end of data transfer cable into E-PEX.



After connecting the cable, the screen of E-CONNECT will display "CONNECTED!", which means the connection is proper.

CONNECTED !



E-PEX need to purchase separately

After connecting E-CONNECT and E-PEX, do the below steps to make sure the device is working normally.



1. Insert the lip hook into the file clip and insert the file into the contra angle.

2. Touch the file with the lip hook (short circuit).

normally, user can hang the lip hook into the patient's mouth, and start the treatment.

3. Press the main switch of E-CONNECT. All the root canal length strips in the screen will light up. That means the system is working normally.

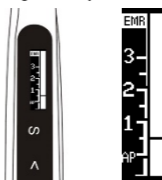

After checking the system can working normally, user can hang the lip hook into

4 Installing the E-CONNECT

the patient's mouth, and start the treatment.

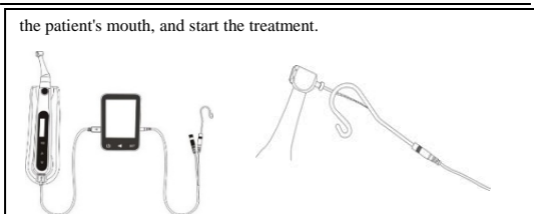

4.4E-CONNECT Charging

The number of cells in the battery symbol shows the current available battery power. When there is only one left, please charge.



Connect the handpiece and adapter as shown below,

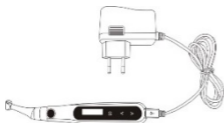

Only the original adapter can be used.

The screen will show  indicating the device is in charging.



- Keep away from the heat source, and make sure that there is no combustible surrounding.
- When the battery power is low or no power, please charge the device. Charging intermittently for short duration multiple times will reduce the battery life.
- Do not use other power adapter to charge the device, otherwise it will damage the device.
- Do not use other battery for the device, otherwise it will damage the device.
- Don't position the device where it is difficult to operate the disconnection device

5.Use Interface

5.1 Panel key

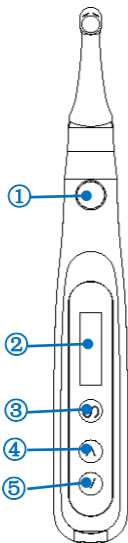

- ① ● Main switch
- ② Display Screen
- ③ S Setting key
- ④ < Decrease key
- ⑤ > Increase key

Turn Power On

Press ● more than 0.5 seconds to turn on the instrument

Memory Change

Press < or > during standby state

Operation mode Change

Press S once during standby state, press < or > to change, then press ● or wait 5 seconds to confirm

Parameter Adjustment

Press S till target parameters, press < or > to adjust, then press ● or wait 5 seconds to confirm

Preset Program Selection

Long press S to entry preset program during standby state, press < or > to change, then press ● to confirm

Turn Power Off

Press ●(Main switch) < (decrease key) to power off.

Advanced setting

During power off state, holding down press S then press ● to entry advanced setting, Press S till target setting, press < or > to adjust, then press ● to confirm.

Keys Function

1) Start E-CONNECT: Press the main switch

Start the device. The display appears the standby interface. After 10 minutes (it could be changed) without any operation, the device will be automatically shut-down.

Press  (Main switch)  (- key) to power off.

2) Choose memory: By press </>



E-CONNECT has 10 memory mode (M0 to M9). Users can set the memory mode (combine different speed, torque and reverse direction) by themselves. Memory M0 is reciprocating mode, there are 5 units reciprocating degrees in M0, press S key to switch. M1-M9 are for normal mode.

3) Start the motor: Press the main switch again

Start the motor. The display appears the torque bar interface.

When the motor is running, the torque bar in real time monitor will appear on the display.

When the torque in file exceeds 70% of the set reverse torque, E-CONNECT will make a discontinuous stone alarm.

When the torque in file reaches 100% of the set reverse torque, E-CONNECT will make a continuous alarm sound and carry out the reverse motion to disengage & carry out the file from the canal.

4) Stop the motor: Press main switch

The motor will stop and return to standby interface.

5.2 Screen display

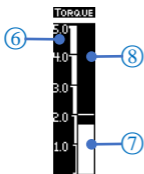
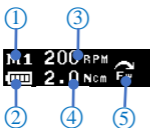

Display standby interface

- ① Memory mode number
- ② Battery Levels
- ③ Running speed
- ④ Reverse torque value
- ⑤ Rotation direction

Display torque interface

- ⑥ Torque scale
- ⑦ Real time torque display bar
- ⑧ Reverse torque cursor

5.3 Display the root canal on E-CONNECT

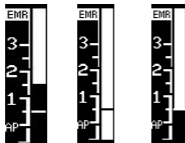

1. The white band on handpiece screen will display the progression of the file into the canals.
2. The closer the file tip to the apical foramen, the more rapid the beep sound makes.
3. After connection, it will activate the advanced setting in 9.5.

5.4 Combination Function



Set "ON" to choose the combination function
 Set on to activate this function, when the file approaches the root canal, the motor will auto start.
 When the file leaves the root canal, the motor will auto stop.



Operator can set **Apical Reverse**, **Apical Slow Down** and **Apical Torque Reduction** functions.

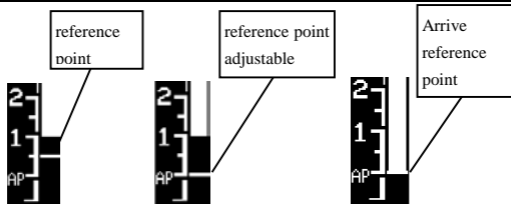

The position of the reference point is automatically set with the E-PEX, and the cursor is displayed on the E-CONNECT screen.

When the file reaches the reference point, E-CONNECT will start **Apical Reverse**, **Apical Slow Down** and **Apical Torque Reduction** function. (If the function is activated).



- Do not use a non-specified data transfer cable, otherwise, it will damage the device.
- Do not hit device and splash liquids on it.



- Make sure to connect the two devices with right position.
- After connecting the two devices with the cable, gently push and pull the interface to ensure that the connection is stable, otherwise the data transmission may not be accurate.
- In certain cases, for example, when the canal is blocked, the measurement may be unable.
- The device will not be able to perform a precise measurement for every time, especially in cases of abnormal or unusual morphology of the root canal. The user needs to coordinate with x-ray to check the results of the measurement.
- If the indicator bar does not move when you enter the file, it is possible that the unit is not working normally, therefore, stop using.

5.5 Terms and definition

Fwd	Forward (Clockwise rotation)
Rev	Reverse (Counter clockwise rotation) Be applied to special file, inject calcium hydroxide and other solutions
REC	Reciprocation Be applied to reciprocating file, path file and rotary file protection by setting some special angle
Reference point	During combined length determination, normally apical reverse must active before reaching major apical foramen, setting apical reverse position by change the flash bar
FWD Angle	Forward angle (Clockwise rotation angle), activating in REC operation mode
REV Angle	Reverse angle (Counter Clockwise rotation angle), activating in REC operation mode
Memory Mode	Such as M0-M9
Operation Mode	Such as FWD, REV, REC

6.Setting

6.1 General function setting

General function: rotate speed, reverse torque, rotate direction

Display the standby interface



Speed setting

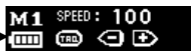

Direction setting

Reverse torque setting

6.2 Operation steps

1. Press +/- to choose a memory number
2. Press the S key to select a function that needs to be set
3. Press +/- to set the parameter that user need.
4. Every time the parameters are changed, it will be saved automatically.



- If there is no operation after 10 seconds (factory setting is 10 seconds, it could be changed), the display will be switched to standby interface.

The speeds (rpm) in different operation mode are not the same, details are listed below.

Fwd	Rev
120	150
200	250
300	350
400	450
500	550
600	650
700	800
900	
1000	

6 Setting

The torques (N·cm) in different operation mode are not the same, and even in the same operation mode, when the speed changing, the possible torque is difference, details are listed below.

Fwd/Rev (120-1000rpm)									
0.5	0.6	0.8	1.0	1.5	2.0	2.5	3.0	3.5	4.0

There are 5 fixed values of reciprocating Angle in M0 reciprocating mode, and the Angle cannot be changed., as shown in the table below.

	Fwd	Rev	REC
reciprocating Angle		/	Five sets of fixed values 1. Fwd angle 30°, Rev angle 150° 2. Fwd angle 150°, Rev angle 30° 3. Fwd angle 180°, Rev angle 30° 4. Fwd angle 210°, Rev angle 30° 5. Fwd angle 250°, Rev angle 30°

Direction setting

Fwd: Clockwise rotation Rev: Counter clockwise rotation



- Please set the parameters according to the file manufacturer's recommendations.
- Use of torque reversal function can effectively protect the file from separating within the canal.
- If the torque reversal is too frequent during the use, please recapitulate, irrigate and lubricate the root canals or increase the torque as per file manufacturer's recommendations.

6.3 Advanced setting

Advanced setting programs installed by the manufacturer are as follows

Function	M1	M2	M3	M4	M5	M6	M7	M8	M9
Apical Reverse	ON	ON	ON	OFF	OFF	ON	ON	OFF	OFF
Auto Start & Stop	ON	ON	ON	ON	ON	ON	ON	ON	ON
Apical Slow Down	OFF	OFF	OFF	ON	ON	OFF	OFF	ON	ON

1. Press +/- to choose a memory number.

2. Long press the S button for more than one second into the advanced function setting interface.

3. Press S switch to next function setting.

4. Press +/- to change parameters.

5. If exceed 5 seconds without any operation (factory setting is 5 seconds, it could be change), display will switch to standby interface

Connect Function
E-CONNECT and E-PEX can be connected to use, the following online function will be activated.

Apical Reverse
Close to root canal apex, automatic reverse / stop.

Auto Start & Stop

When the file enters the root canal orifice, the motor will start running automatically. When the file leaves the canal orifice, the motor will stop automatically.

Apical Slow Down

Automatic deceleration when the file reaches to the root canal apex.



- This function is activated only when the E-PEX is connected.

6.4 Additional function settings

Factory set as shown below:

Beep volume	Mid	Right hand or left hand	Right hand
Automatic shutdown time	10 mins	Automatic standby time	10s

1. When the device is shutdown press key S and main switch at the same time.
2. Press S, choose one of these functions to setting.
3. Press +/- to set the parameters.
4. Press main switch, back to standby interface

Beep Volume
Press + and - to set low, mid or high volume

Auto P.W.R
For a period of time without any operation, the device will be automatically shut down, by press +/- to set automatically shut down time (1~15mins)





Hand
Change the left or right hand interface, the screen will be reversed.

Return to standby time
By press +/- to change the standby time (1-15s)

Calibration

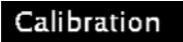

By press +/- to select the 'ON' then press main switch to activate the calibration program.

6.5 Calibration

	<ol style="list-style-type: none"> 1. Install the contra angle into the E-CONNECT handpiece <div style="background-color: #cccccc; padding: 5px; margin: 5px 0;">  <ul style="list-style-type: none"> ● Do not insert the file. </div> <ol style="list-style-type: none"> 2. Enter the calibration option interface (See 9.5 Additional function settings)
	<ol style="list-style-type: none"> 3. press Main switch KEY enter calibration mode, now display will show "calibration".
	<ol style="list-style-type: none"> 4. In calibration, it will display the progress
	<ol style="list-style-type: none"> 5. After calibration, the progress bar will be full, accompany 2 buzzing sound.

7. Error Warning

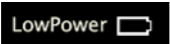
While operating, E-CONNECT will detect the real time performance of the system, if the state is unsuitable, the device will self-protect and inform user.

	<p>The power is too low, there will be auto power off, charge the device immediately.</p> <p>According to the use state of the battery, the battery can be recharged 300-500 times, and then the battery power will be significantly reduced.</p>
	<p>Error code 00, means overload, motor is over current, should reduce the load.</p>
	<p>Error code 01, means the continuous operation time is too long, motor is over heated, stop using the device for some time.</p>



- Please set the functions according to the requirements as dictated by the manufacturer.
- It is recommended to perform a calibration operation after each change of the bending head.
- Please keep the battery in more than half when calibrating.
- Do not apply pressure to the bending head during calibration.
- If the error alarm has occurred, please contact the local distributor to check and repair.

8.Cleaning, Disinfection and Sterilization

8.1 Foreword

For hygiene and sanitary safety purpose, the components (Contra Angle , Insulating Sleeve) must be cleaned, disinfected and sterilized before each usage to prevent any contamination. This concerns the first use as well use the subsequent uses.

Comply with your national guidelines, standards and requirements for cleaning, disinfection and sterilization.

Reprocessing procedures have only limited implications to this dental instrument. The limitation of the numbers of reprocessing procedures is therefore determined by the function / wear of the device. From the processing side there is no maximum number of allowable reprocessing. The device should no longer be reused in case of signs of material degradation. In case of damage, the device should be reprocessed before sending back to the manufacturer for repair.

8.2General recommendations

- The user is responsible for the sterility of the product for the first cycle and each further usage as well as for the usage of damaged or dirty instruments, where applicable after sterility.
- For your own safety, please wear personal protective equipment (gloves, safety glasses, etc.).
- Use only a disinfecting solution which is approved for its efficacy (VAH/DGHM-listing, CE marking, and FDA approval) and in accordance with the DFU of the disinfecting solution manufacturer.
- The water quality has to be convenient to the local regulations especially for the last rinsing step or with a washer-disinfector.

- Thoroughly clean and wash the components before autoclaving.
- Do not use bleach or chloride disinfectant materials.

Autoclavable Components



- Only the components above can be autoclaved.
- Before first use and after each use, sterilize the above components heat sources.

Autoclave Procedure:

Reprocessing Instructions

Preparation at the Point of Use

Disconnect the components (Contra Angle, Insulating Sleeve) from the handpiece. Remove gross contaminations from the components with code water (<math><40^{\circ}\text{C}</math>) immediately after use. Don't use a fixating detergent or hot water (>math>>40^{\circ}\text{C}</math>) as this can cause the fixation of residuals which may influence the result of the reprocessing process. Store the instruments in a humid surrounding.



- Do not submerge the components or wipe them with any of the following functional water

8 Cleaning, Disinfection and Sterilization

	<p>(acidic electrolyzed water, strong alkaline solution, or ozone water), medical agents (glutaral, etc.), or any other special types of water or commercial cleaning liquids. Such liquids may result in metal corrosion and adhesion of the residual medical agents to the components.</p>
Transportation	<p>Safe storage and transportation to the reprocessing area to avoid any damage and contamination to the environment.</p>
Preparation for Decontamination	<p>The devices must be reprocessed in a disassembled state.</p>  <ul style="list-style-type: none"> ● Do not fail to take out the file before cleaning the contra angle. ● Observe suitable personal protective measures.
Pre-Cleaning	<p>Do a manual pre-cleaning, until the components are visually clean. Submerge the components in a cleaning solution and flush the lumens with a water jet pistol with cold tap water for at least 10 seconds. Clean the surfaces with a soft bristol brush.</p>
Cleaning	<p>Regarding cleaning/disinfection, rinsing and drying, it is to distinguish between manual and automated reprocessing methods. Preference is to be given to automated reprocessing methods, especially due to the better standardizing potential and industrial safety.</p> <p>Automated Cleaning: Use a washer-disinfector meeting the requirements of the ISO 15883 series.</p>

Carefully put the instrument into the washer-disinfector on a tray and set the parameters as follows and start the program:

- 4 min pre-washing with cold water (<40°C)
- emptying
- 5 min washing with a mild alkaline cleaner at 55°C
- emptying
- 3 min neutralising with warm water (>40°C)
- emptying
- 5 min intermediate rinsing with warm water (>40°C)
- emptying

The automated cleaning processes have been validated by using 0.5% neodisher MediClean forte (Dr. Weigert).

Note Acc. to EN ISO 17664 no manual reprocessing methods are required for these devices. If a manual reprocessing method has to be used, please validate it prior to use.





- Use only approved washer-disinfectors according to EN ISO 15883, maintain and calibrate it regularly.
- Follow instructions and observe concentrations given by the manufacturer (see general recommendations).
- Avoid any contact between the contra angle and any instrument, kit, support or container.

8 Cleaning, Disinfection and Sterilization

Disinfection	<p>Automated Thermal Disinfection in washer/disinfector under consideration of national requirements in regards to A0 value (see EN ISO 15883).</p> <p>A disinfection cycle of 5 min disinfection at 93°C has been validated for the device to achieve an A0 value of 3000.</p> <p>After manual cleaning, the instrument should be automated disinfected or sterilized immediately. A manual disinfection is not recommended.</p>
Drying	<p>Automated Drying:</p> <p>Drying of outside of instrument through drying cycle of washer/disinfector. If needed, additional manual drying can be performed through lint free towel. Insufflate cavities of instruments by using sterile compressed air.</p>
Functional Testing, Maintenance	<p>Visual inspection for cleanliness of the components and reassembling. Functional testing according to instructions of use. If necessary, perform reprocessing process again until the component is visibly clean.</p> <p>Before packaging and autoclaving, make sure that the device has been maintained acc. to the manufacturer's instruction.</p> <p>Only the contra angle needs to be lubricated.</p> 

8 Cleaning, Disinfection and Sterilization

	 <ul style="list-style-type: none">● Before autoclaving, the contra angle must be lubricated.● Attaching the spray nozzle to oil can and contra angle, press the oil can button more than 3 seconds, till all the black oil flow out from the head of the contra angle.
Packaging	<p>Pack the instruments in an appropriate packaging material for sterilization.</p>  <ul style="list-style-type: none">● Check the validity period of pouch given by the manufacturer to determine the shelf life.● Use pouches which resist to a temperature up to 141°C and in accordance with EN ISO 11607.
Sterilization	<p>Sterilization of instruments by applying a fractionated pre-vacuum steam sterilization process (according to EN 285/EN 13060/EN ISO 17665) under consideration of the respective country requirements.</p> <p>Minimum requirements: 3 min at 134 °C (in EU: 5 min at 134 °C)</p> <p>Maximum sterilization temperature: 137°C</p> <p>Flash sterilization is not allowed on lumen instruments!</p>  <ul style="list-style-type: none">● Use only approved autoclave devices according to EN 13060 or EN 285.● Use a validated sterilization procedure according to EN ISO 17665.

8 Cleaning, Disinfection and Sterilization

	<ul style="list-style-type: none"> ●Respect the maintenance procedure of the autoclave device given by the manufacturer. ●Use only this recommended sterilization procedure. ●Control the efficiency (packaging integrity, no humidity, color change of sterilization indicators, physicochemical integrators, digital records of cycles parameters). ●The sterilization procedure must comply with EN ISO 17665. ●Wait for cooling before touching.
Storage	<p>Storage of sterilized instruments in a dry, clean and dust free environment at modest temperatures, refer to label and instructions for use.</p>  <ul style="list-style-type: none"> ●Sterility cannot be guaranteed if packaging is open, damaged or wet. ●Check the packaging and the contra angle before using it (packaging integrity, no humidity and validity period).
Reprocessing validation study information	<p>The above-mentioned reprocessing process (cleaning, disinfection, sterilization) has been successfully validated. Refer to test reports:</p> <ul style="list-style-type: none"> - Changzhou Sifary _Cleaning Disinfection Validation Report - Changzhou Sifary _Sterilization Validation Report_Contra angle - Changzhou Sifary _Sterilization Validation Report_File clip - Changzhou Sifary _Sterilization Validation Report_Insulating sleeve



- The instructions provided above have been validated by the manufacturer of the medical device as being capable of preparing a medical device for use. It remains the responsibility of the processor to ensure that the processing, as actually performed using equipment, materials and personnel in the processing facility, achieves the desired result. This requires verification and/or validation and routine monitoring of the process. Likewise, any deviation by the processor from the instructions provided should be properly evaluated for effectiveness and potential adverse consequences.

8.3 Disinfection

<div data-bbox="122 765 448 1141"> <p>Wipe with Ethanol for Disinfection (Ethanol 70 to 80 vol%)</p> <p>Mortar Handpiece & Handpiece Base</p> <p>Data transfer cable Adapter</p> </div>	<p>Wipe all the surfaces with a cloth lightly moistened with Ethanol for Disinfection (Ethanol 70 to 80vol%) at least 2 min, repeat for 5 times.</p>
	<div data-bbox="484 890 557 953"> </div> <ul style="list-style-type: none"> ● Do not use anything except Ethanol for Disinfection (Ethanol 70 to 80 vol%). ● Do not use too much ethanol as it's going into machine and damage the components inside.

9.Troubleshooting

When trouble is found, check the following points before contacting your distributor. If none of these are applicable or the trouble is not remedied even after action has been taken, the product may have failed. Contact your distributor.

Problem	Cause	Solution	Ref. chap
The power is not turned on.	The battery is flat.	Charge the battery.	7
	Press the main switch too short time.	Press the main switch more than 0.5 seconds.	5.1
Handpiece screen does not appear	The handpiece broken.	Check if there is a sound of beep or motor, and Contact your distributor.	/
The motor doesn't rotate.	The contra angle is clogged	Clean or replace the contra angle.	/
Motor spontaneously starts running in reverse.	Up to setting torque limit.	Check the torque limit is enough or not.	6.1
	Setting to REV mode.	Change setting if it's not expected.	6.1
Motor does not reverse.	Torque reverse setting might be too high.	Change setting if it's not expected.	6.1
Motor alternates between forward and	Operation mode setting to REC	Change setting if it's not expected.	5.5

9 Troubleshooting

reverse rotation.			
Sound too low	Beep volume set to low.	Set beep volume to, mid or high	6.4
Beep sound an alarm even though the instrument is not being used.	The motor is set to REV	If it is the expected mode, ignore the alarm.	6.1

10. Technical Data

Manufacturer	Changzhou Sifary Medical Technology Co.,Ltd
Model	E-CONNECT
Dimensions	21.4cm x 9.98cm x10cm±1cm (package)
Gross weight	690g ±10%
Contra angle	Gear ratio: 1:1 Compatible with rotary and reciprocating instruments, equipped with \varnothing 2.35 mm nickel titanium root canal file conforming to ISO 1797:2017, Type 1, Files length 11-31mm.
Power supply	Lithium ion battery: 3.7V, 1500mAh
European standard adapter	Model No: UE05LV2-050100SPA Input: AC 100-240 V,50/60Hz,0.2A Output: DC 5V/1A, 5W
Multi-standard adapter	Model No: UES06WOCP-050100SPA Input: AC 100-240 V, 50/60Hz, 0.2A Output: DC 5V/1A
Torque range	0.5N.cm-4N.cm
Speed range of the micromotor shaft	120-1000 rpm
Electrical safety class	Class II at charging mode; Internally powered device at running mode.
Applied part	B (Contra angle, Insulating Sleeve)
Operation mode	Non-continuous, duty cycle: ON 5 mins, OFF 5 mins
Ambient conditions	Use: in enclosed spaces Ambient temperature: 10°C ~ 40 °C Relative humidity: 30% ~ 75%

10 Technical Data

	Atmospheric pressure: 70kPa~106kPa
Transport and storage conditions	Ambient temperature: -20 °C ~ +55 °C Relative humidity: 20% ~ 80%, non-condensing Atmospheric pressure: 70 kPa ~ 106 kPa

11.EMC Tables

Guidance and manufacturer's declaration – electromagnetic emissions

The **E-CONNECT** is intended for use in the electromagnetic environment specified below. The customer or the user of the **E-CONNECT** should assure that it is used in such an environment.

Emissions test	Compliance	Electromagnetic environment - guidance
RF emissions CISPR 11	Group 1	Professional healthcare facility environment and Home healthcare environment
RF emissions CISPR 11	Class B	Professional healthcare facility environment
Harmonic emissions IEC61000-3-2	Class A	
Voltage fluctuations/flicker emissions IEC 61000-3-3	Complies	



The EMISSIONS characteristics of this equipment make it suitable for use in industrial areas and hospitals (CISPR 11 class A). If it is used in a residential environment (for which CISPR 11 class B is normally required) this equipment might not offer adequate protection to radiofrequency communication services. The user might need to take mitigation measures, such as relocating or re-orienting the equipment.

Guidance and manufacturer's declaration – electro-magnetic immunity			
The E-CONNECT is intended for use in the electromagnetic environment specified below. The customer or the user of the E-CONNECT should assure that it is used in such an environment.			
Immunity test	IEC 60601 test level	Compliance level	Electromagnetic environment - guidance
Electrostatic discharge (ESD) IEC 61000-4-2	+/- 8 kV contact +/- 2 kV, +/- 4 kV, +/- 8 kV, +/- 15 kV air	+/- 8 kV contact +/- 2 kV, +/- 4 kV, +/- 8 kV, +/- 15 kV air	Floors should be wood, concrete or ceramic tile. If floors are covered with synthetic material, the relative humidity should be at least 30 %.
Electrical fast transients/bursts IEC 61000-4-4	± 2 kV 100kHz repetition frequency	± 2 kV 100kHz repetition frequency	Mains power quality should be that of a typical commercial or hospital environment.

11 EMC Tables

<p>Rated Power frequency magnetic field IEC 61000-4-8</p>	<p>30 A/m 50Hz or 60Hz</p>	<p>30 A/m 50Hz or 60Hz</p>	<p>Power frequency magnetic field should be at levels characteristic of a typical location in a typical commercial or hospital environment.</p>
<p>Note: UT: rated voltage(s); E.g. 25/30 cycles means 25 cycles at 50Hz or 30 cycles at 60Hz</p>			

Guidance and manufacturer's declaration – electromagnetic immunity

The **E-CONNECT** is intended for use in the electromagnetic environment specified below. The customer or the user of the **E-CONNECT** should assure that it is used in such an environment.

Immunity test	IEC 60601 test level	Compliance level	Electromagnetic environment - guidance
Conducted disturbances induced by RF fields IEC 61000-4-6	3 V 0.15 MHz – 80 MHz, 6 V in ISM bands between 0.15 MHz and 80 MHz, 80 % AM at 1 kHz	3 V	Portable and mobile RF communications equipment should be used no closer to any part of the E-CONNECT, including cables, than the recommended separation distance calculated from the equation applicable to the frequency of the transmitter.
Radiated RF EM fields IEC 61000-4-3	3 V/m, 80 MHz – 2,7 GHz, 80 % AM at 1 kHz See the RF wireless communication	3V/m	Recommended minimum separation distances See the RF wireless communication equipment table in "Recommended

Proximity fields from RF wireless communication equipment IEC 61000-4-3	ation equipment table in "Recommended minimum separation distances"	Complies	minimum separation distances"
---	---	----------	-------------------------------

Recommended minimum separation distances

Nowadays, many RF wireless equipments have being used in various healthcare locations where medical equipment and/or systems are used. When they are used in close proximity to medical equipment and/or systems, the medical equipment and/or systems' basic safety and essential performance may be affected. The **E-CONNECT** has been tested with the immunity test level in the below table and meet the related requirements of IEC 60601-1-2. The customer and/or user should help keep a minimum distance between RF wireless communications equipments and the **E-CONNECT** as recommended below.

Test frequency (MHz)	Band (MHz)	Service	Modulation	Maximum power (W)	Distance (m)	Immunity test level (V/m)
385	380-390	TETRA 400	Pulse modulation 18Hz	1.8	0.3	27
450	430-470	GMRS 460 FRS 460	FM ± 5 kHz deviation 1 kHz sine	2	0.3	28
710	704-787	LTE Band 13, 17	Pulse modulation 217Hz	0.2	0.3	9
745						
780						
810				2	0.3	28

11 EMC Tables

870	800-960	GSM 800/900, TETRA 800, iDEN 820, CDMA 850, LTE Band 5	Pulse modulation 18Hz			
930						
1720	1700-1990	GSM 1800; CDMA 1900; GSM 1900; DECT; LTE Band 1, 3, 4, 25; UMTS	Pulse modulation 217Hz	2	0.3	28
1845						
1970						
2450	2400-2570	Bluetooth, WLAN, 802.11 b/g/n, RFID 2450,	Pulse modulation 217Hz	2	0.3	28

		LTE Band 7				
5240	5100- 5800	WLAN 802.11 a/n	Pulse modula tion 217Hz	0.2	0.3	9
5500						
5785						

Guidance and manufacturer's declaration – electromagnetic immunity

The **E-CONNECT** is intended for use in the electromagnetic environment specified below. The customer or the user of the **E-CONNECT** should assure that it is used in such an environment.

Proximity magnetic fields	IEC 61000-4-39 test level	Compliance level	Electromagnetic environment – guidance
Proximity magnetic fields	134.2k Hz Pulse modulation 2.1 kHz	65A/m	Power frequency magnetic field should be at levels characteristic of a typical location in a typical commercial or hospital environment.
Proximity magnetic fields	13.56M Hz Pulse modulation 50 kHz	7.5A/m	



- Use of accessories and cables other than those specified or provided by the manufacturer of E-CONNECT could result in increased electromagnetic emissions or decreased electromagnetic immunity of E-CONNECT and result in improper operation.

Cable information:

Cable Name	Cable Length (m)	Shielded or not	Remark
Adapter Cable	1.2	No	/
Measuring Wire	1.5	No	/

- Use of E-CONNECT adjacent to or stacked with other equipment should be avoided because it could result in improper operation. If such use is necessary, E-CONNECT and the other equipment should be observed to verify that they are operating normally.
- Portable RF communications equipment (including peripherals such as antenna cables and external antennas) should be used no closer than 30 cm (12 inches) to any part of the E-CONNECT, including cables specified by the manufacturer. Otherwise, degradation of the performance of this equipment could result.
- If the use location is near (e.g. less than 1.5 km from) AM, FM or TV broadcast antennas, before using this equipment, it should be observed to verify that it is operating normally to assure that the equipment remains safe with regard to electromagnetic disturbances throughout the expected service life.

12.Statement

Service Life

The service life of E-CONNECT series products is 3 years.

It is recommended that the equipment be checked and repaired at the dealer once a year.

Maintenance

MANUFACTURER will provide circuit diagrams, component part lists, descriptions, calibration instructions to assist to SERVICE PERSONNEL in parts repair.

Disposal

The package should be recycled. Metal parts of the device are disposed as scrap metal. Synthetic materials, electrical components, and printed circuit boards are disposed as electrical scrap. The lithium batteries are disposed as special refuse. Please deal with them according to the local environmental protection laws and regulation.

Rights

All rights of modifying the product are reserved to the manufacturer without further notice. The pictures are only for reference. The final interpretation rights belong to Changzhou Sifary Medical Technology Co., Ltd. The industrial design, inner structure, etc, have claimed for several patents by SIFARY, any copy or fake product must take legal responsibilities.



Changzhou Sifary Medical Technology Co., Ltd.

Add: NO.99 Qingyang Road, Xuejia County, Xinbei District
Changzhou, 213000 Jiangsu,P.R. China

Tel: +86-0519-85962691

Fax: +86-0519-85962691

Email: info@sifary.com

Web: www.sifary.com



Caretechion GmbH

Tel: +49 211 2398 900

Add: Niederrheinstr. 71, 40474 Düsseldorf, Germany

Email: info@sifary.com

All rights reserved.